



KANSAS CITY

KCI Auto Auction

Arbitration Policy:

In-Lane and Online

February 2010
Revision 2.0

National Arbitration Policy



I. General Policies

1. **Fair and Ethical Sale:** The sales made at an Auction are intended to promote fair and ethical treatment to both the Buyer and Seller. If Auction determines that the transaction is not fair and ethical to either party, the Seller and the Buyer agree that Auction may cancel the sale, at its sole discretion. Federal, State, and Local laws supersede these policies where applicable. This provision also applies to any clerical or administrative error made by Auction. Any arbitration conducted at Auction is subject to the Terms and Conditions of the Auction.
2. **Auction Role in Sale:**
 - a. Auction makes no representations or guarantees as to the description, equipment, warranties, service policy, title status/accuracy, or odometer on any vehicle sold or offered for sale.
 - b. Auction is not a party to the contract of the sale. The sales contract is between the Seller and Buyer only. The Seller is required to give the Federal Odometer Mileage Statement in connection with any auction sale as required by the Motor Vehicle Information and Cost Savings Act of 1972 or any other applicable laws. Auction is not responsible for the accuracy of odometer readings, odometer statements, or damage disclosure statements.
 - c. All vehicles bought or sold on the premises must be processed through the Auction office. Failure to do so will result in suspension of trading privileges at Auction.
3. **Lot Sales/ Outside Sales**
 - a. Any sale in which the Auctioneer does not state the selling price of the vehicle or “sell under the hammer” is considered a “Lot Sale”.
 - b. All “Lot Sales” are conditional until the buyer signs the block ticket or appropriate document for the vehicle signifying they have inspected and accepted the vehicle. Until the appropriate document is signed, the sale is not binding to either party.
 - c. Sellers may guarantee “Lot Sales”, but must do so in writing. Vehicles sold after crossing the block are still subject to the announced conditions noted on the Auction sales receipt. These transactions are subject to the terms noted in the Disclosure/Discovery section of the policies.
 - d. Buyers are cautioned to inspect “Lot Sale” vehicles very carefully and verify announced conditions before purchasing. A Post Sale Inspection (PSI) may be purchased on “Lot Sales”.
4. **Auction VIN Policies**
 - a. All vehicles consigned must have a public Vehicle Identification Number (VIN) plate attached to the vehicle. Those vehicles having a reassigned VIN plate by the State in place of the original VIN plate must be announced or will be subject to sale cancellation or Buyer return. Auction reserves the right to refuse the sale of any vehicle in which the VIN plate appears to be altered in any way.
 - b. Seller guarantees VIN plates and years on any vehicle up to 20 model years old with the exception of the VIN plates and year on trailers, RVs, and watercraft, which are guaranteed up to 10 model years.
5. **Auction Right of Review** - Auction reserves the right to review any audio/video documentation to verify the accuracy of a sale.
6. **Auction Exclusions**
 - a. Auction is not bound by information listed in Electronic Data Vehicle Histories (EDVH) (i.e. Carfax, AutoCheck, etc.) and any vehicle may not be arbitrated solely on EDVH data. Auction may investigate vehicle history based on information found in EDVH for information that may impact arbitration.

- b. Vehicles are not subject to arbitration if they exceed 20 model years, with the exception of trailers, RVs, and watercraft, which cannot be arbitrated if they exceed 10 model years.
- c. Kit vehicles, homemade vehicles, or modified vehicles are sold “AS-IS” and cannot be arbitrated for odometer, frame, VIN plates, warranty books, or model year.

7. Online Buyer Responsibilities

- a. The Buyer or Buyer’s agent (transporter or driver) should note any obvious damage on the gate release prior to removing the vehicle from the Auction or facilitation service provider’s location. Auction or facilitation service provider and Seller will not be responsible for any obvious damage not identified on the gate release or the condition report once the vehicle is removed from the Auction or facilitation service provider’s location.
 - b. Buyer will inspect the vehicle immediately upon arrival at Buyer’s location. The Buyer must verify the Seller’s representations and notify the Auction or facilitation service provider immediately of any discrepancies within the time frame as stated in this arbitration policy. Buyer will verify odometer reading upon arrival at Buyer’s location. Mileage must be the same as when purchased if arbitrating for inoperable odometer.
 - c. The Buyer is responsible for understanding the Online Bidding/Proxy Bidding and Buy Now procedures for online buying channels
 - d. It is strongly encouraged that an On-Line Buyer should have a Post Sale Inspection (PSI) on vehicles purchased.
8. **Government Inspection** - All vehicles registered/sold at Auction are subject to inspection, with or without prior notice, by the FBI, State Police, National Auto Theft Bureau, Local Police Authorities, any other governmental agency, or quasi-governmental agency.
9. **Buyer Responsibilities** - The Buyer is responsible for listening to announcements related to each vehicle, made by the Auctioneer or Selling Representative, prior to the start of the sale. The Buyer is also responsible for observing and understanding the sale lights (Green, Yellow, Red, Blue), which identify various sale conditions for the vehicle.
10. **Seller Responsibilities** - All guaranties as stated by the Seller are those of the Seller only. The Seller understands that the sale light/video display is a binding arbitration representation of vehicle condition, and is therefore responsible for ensuring that their vehicles sell under the correct light in the lane.

II. Sale-Light / Video Display Systems: In-Lane and Online Simulcast Only

1. **Auction System** – Auction has a standardized light/video display system to describe the condition and/or announcements related to the vehicle being sold. The system is defined as:
- a. **Green Light – “Ride and Drive”**: The green light signals that this vehicle is guaranteed under the conditions outlined in the Disclosure/Discovery Arbitration section, except for specific announcements made prior to the sale.
 - b. **Yellow Light – “Announcements”**: This light is an indication to the Buyer that the Auctioneer or Selling Representative has made announcements that qualify/clarify the condition or equipment and limit arbitration of this vehicle.
 - c. **Red Light – “AS-IS”**: Vehicles selling under the red light will only qualify for arbitration under the rules outlined in the Disclosure/Discovery section. Any vehicle that sells for \$2000 or less, will automatically be sold “AS-IS”.

- d. **Blue Light – “Title Attached/Title Unavailable/Title Absent”:** This light is used to announce that the title is not present at the time of the sale. For Auction rules regarding titles please refer to the Title Arbitration Policy section. If “title attached/unavailable/absent” is not announced, a vehicle could be arbitrated for misrepresentation.

III. Disclosure / Discovery Requirements

Arbitration Guidelines

Vehicles that have any of the following defects, conditions, or discrepancies that were not disclosed or announced at the time of sale must be reported to Auction within the time frame noted below in order to be eligible for arbitration. The only exception is if there is a pending Post Sale Inspection (PSI). Vehicles must be returned to Auction in the same or better condition than when purchased.

1. **By Sales Channel** – Some arbitration policies are sales channel specific. The two sales channels are defined as follows:
 - a. **In-Lane:** All purchases made by a bidder on Auction location property. Vehicles purchased in an online event sale by bidders at a location will be considered “in-lane”.
 - b. **On-Line:** Defined as purchases made by a remote bidder via the internet. Due to the differences associated with purchasing through online channels, such as the inability of the buyer to view the vehicle, additional time parameters and damage disclosure requirements for arbitration have been included.
2. **Time Period:** Definition codes for discovery time periods as set forth below in the **Arbitration Matrix (Appendix I)**:
 - a. All Online arbitrations must be initiated within 2 calendar days of Buyer’s verified receipt of the vehicle and cannot exceed 10 calendar days from purchase. Purchase of a Post Sale Inspection (PSI) may increase arbitration timeframes of items covered in the PSI. It is the auction or facilitation service provider’s responsibility to inform Seller of any pending PSI or arbitration resulting from the Sale.
 - b. Sale day is day 1.
 - c. Arbitration shall end at the closing time on the last calendar day in the time period. Below are the definitions of the time codes referred to in the Arbitration Matrix Table at the end of this document.
 - i. (A) In-lane – Sale day only. Arbitration period ends at 4:00 pm. On non-Thursday sale events, arbitration period ends 2 hours after time of purchase.
 - ii. (B) In-lane – 7 calendar days
 - iii. (C) Online – 2 calendar days upon verified arrival to Buyer not to exceed 10 calendar days from purchase.
3. **Process** - The arbitrator will inspect only the defect(s) which are on the arbitration form/documents. Each vehicle transaction is allowed one chance at mechanical, electrical, or cosmetic arbitration. If price adjustment is made and accepted, vehicle becomes “AS-IS” property of the Buyer, and is not subject to any further arbitration for mechanical, electrical, or cosmetic defects or adjustments. The decision of the arbitrator is final and binding to both Buyer and Seller.
4. **Fees** - Auction reserves the right to assess an arbitration fee to the Buyer. Any arbitration must be properly documented in writing and signed by the arbitrator. If the arbitration is valid, Auction reserves the right to assess an arbitration fee to the Seller. This fee is in addition to any charges associated with the arbitration procedure; such as check out fees at a specialty shop or transportation costs to and from a garage, etc.
5. **Exclusions:**
 - a. **Noise and Inherent Conditions:** No arbitration can be based on noises or conditions that are inherent or typical to a particular model or manufacturer, unless deemed “excessive” by the arbitrator on non-warranty items. OEM dealer warranty guidelines will be used where applicable to determine whether the condition is excessive.

- b. **Manual Transmissions:** Vehicles with standard transmissions cannot be arbitrated for manual clutches unless the defect will not allow a safe test drive.
 - c. **Wearable Items:** Auction will not arbitrate vehicles for wearable items. For purposes of this policy wearable items are defined as parts of the vehicle that the manufacturer recognizes the need for replacement/adjustment during the expected life of the vehicle. These items are normally identified in the Owner's Manual for routine check and replacement and would include, but not limited to: tires, wipers, brake pads, shoes, rotors, belts, hoses, lubricants/fluids, timing belts, bulbs, filters, shocks & struts.
 - d. **As-Is:** Any in-lane or online vehicle sold "AS-IS" is NOT subject to mechanical, electrical, or cosmetic arbitration. AS-IS selling price, model years, and mileage is subject to local auction policy.
 - e. **Unsafe vehicles:** Auction reserves the right to reject any vehicle that management judges to be unsafe.
6. **4x2 Disclosure Rule:** All multipurpose and utility-type vehicles are assumed to be 4X2 unless otherwise announced. However, if a 4X2 multipurpose, utility-type vehicle or pickup has been altered in appearance or stance to resemble a 4X4, a 4X2 announcement will be required. Examples include: new badges, raised suspension, and off-road tires.
7. **Arbitration by Selling Channels:**
- a. **All Selling Channels** - Seller will be held responsible for the accuracy and completeness of all representations or descriptions. This includes handouts, catalogues, vehicle markings, and verbal or written statements made by Seller or Auctioneer at the time of sale, independent of vehicle "light" designation or guarantee offered. This includes all vehicles offered for sale either in-lane or on the internet including all images and text representations made by Seller, designee or Seller's agent including 3rd party condition reports or vehicle listing agents at the time of sale. This includes, but is not limited to year, make, model, odometer reading, equipment, and announced conditions. Repair costs will be determined by the auction and will reflect the auction cost to repair.
 - b. **In-Lane:** Any single mechanical or electrical defect that has a repair cost of \$500 or more is subject to arbitration on Green Light vehicles. Single defects less than \$500 are deemed minor and not subject to arbitration. Auction will not arbitrate visible defects or announced conditions.
 - c. **Online:** Sellers who sell to online buyers through any of the online channels and provide a condition report have the additional responsibility to disclose defects or damage that are "visible" in nature. The Seller must disclose damage (but not actual repair cost) with a cumulative auction (wholesale) repair cost in excess of \$500. Undisclosed cumulative damage in excess of \$500 is subject to arbitration by the Buyer due to an inadequate disclosure of damage or condition. Actual images of the listed vehicle must be used unless proper disclosure is noted by the Seller which makes it known the actual vehicle is not shown.
 - d. **Online Without Vehicle Condition Information** - Vehicles sold through online channels without a written condition report, inspection, or a disclosure as to the vehicle's condition, will be subject to In-Lane policies (b) as detailed in this policy.
8. **Seller Fees:** The Seller is responsible for reimbursement of all reasonable documented expenses incurred by the Buyer (excluding profit, commissions, and detail charges) on vehicles arbitrated for unannounced conditions not detectable through vehicle inspection (i.e. stolen vehicle, theft recovery, odometer discrepancy, title discrepancy, frame damage, flood damage, salvage, manufacturer buyback, etc.). Expense reimbursements will be at the sole discretion of Auction and will, at times be limited to reasonable and documented expenses and transportation only.
9. **Buyer Responsibilities and Liabilities:**
- a. It is the Buyer's responsibility to watch lights and listen to announced conditions before placing bids. Once the vehicle is sold the Buyer should check the Auction sales receipt to confirm the vehicle price and announcements are correct before legibly printing and signing their name or electronically signing the Auction sales receipt

- b. Buyers should thoroughly check and, if possible, test drive every vehicle. If there is any problem, a complaint must be properly filed with the Arbitration Office within the established arbitration time limit. The Buyer assumes responsibility for mechanical or electrical failure once the arbitration period is over.
- c. Buyer agrees to be liable for any and all work done to a vehicle prior to returning the vehicle to Auction except on vehicles arbitrated for unannounced conditions not detectable through vehicle inspection. (i.e. stolen vehicle, odometer, theft recovery, title brands, title discrepancy – does not include title attached/unavailable/absent). Mileage must be the same as it was when it left Auction if arbitrated for inoperable odometer. Vehicle must be returned in a timely manner consistent with auction direction.
- d. The Buyer is financially responsible for any pending sale until arbitration is final.

- 10. Manufacturer's Warranty:** The availability of a manufacturer's warranty shall not affect a Buyer's right to arbitrate a vehicle.
- 11. Auction Notice** - The Buyer shall not surrender possession of the vehicle to any claimant, except as required by legal process, nor shall Buyer voluntarily pay or acknowledge the validity of any claim, without the prior approval of Auction. Time is of the essence. Any failure on the part of the Buyer, after becoming aware of said claim, to notify Auction of any claim in a timely manner or failure of the Buyer to cooperate in defending any such claim shall relieve Auction of any liability under this policy.
- 12. Payment in Arbitration** - Seller will not be paid for vehicles in arbitration until arbitration is settled, and vehicles are sold. For arbitrations occurring after the seller has been paid, seller is required to promptly return the payment to the auction if the transaction is voided as a result of arbitration.
- 13. Return Process** - A vehicle is not considered returned until received, inspected, and approved for return by Auction management. Any vehicle returned must be in the same or better condition as when sold. Any vehicles delivered to and left on Auction premises without Auction approval remain the sole responsibility of the Buyer. Buyer assumes all risk of loss.
- 14. Fees on Returned Vehicle** - There may be a charge for excessive mileage on a returned vehicle (*at the discretion of Auction*).

IV. Title Arbitration Policy

1. **Seller Title Responsibilities:** All titles submitted by Seller must be in Seller's company name on title or on a properly executed reassignment form. The Seller guarantees the titles of vehicles that are sold through Auction. This guarantee of the title warrants that the title shall be marketable and free and clear of all liens and encumbrances. This includes any brand (such as 'salvage') noted upon the current or any prior certificate of title unless such encumbrances were announced at the time the vehicle is sold through Auction and for a period of four (4) years from the date of sale. Seller's liability under this title guarantee shall never exceed the Auction sale price (the "maximum amount") of the vehicle, and this maximum amount shall be reduced by two percent (2%) per month following Auction sale date. All liability under this title guarantee shall expire and terminate 48 months after Auction sale date. Auction will not be responsible for any expenses incurred on vehicles returned for late title.
2. **Seller's Title Guarantee:** Sellers warrant, represent and guarantee that they have and will convey a certificate of title, properly executed, valid in the state where the transaction is occurring and clear of all liens and encumbrances (except current year DMV fees in California), and that he will warrant and defend the title against the claims and demands of all persons whatsoever.
3. **Auction Right to Remediate Clerical Error** – If the title problem is due to a clerical or coding error, or incomplete documentation, Auction shall be given reasonable time after receiving notice to have the error corrected.
4. **Buyer's Title Claim Notice to Auction** – Whenever any claim is made by any person against the title of a vehicle, whether by suit or otherwise, the Buyer, after becoming aware of said claim, shall immediately notify Auction. This involves giving full particulars of claim, cooperating fully in defending any legal action, and in taking other steps to minimize possible loss.

5. **Title Assignment** - Title must be reassigned directly to Buyer. No title assigned directly to Auction will be accepted.
6. **Payment After Title Receipt** - Seller will not be paid for vehicles until a transferable title is received.
7. **Non-titled Vehicles Rules:**
 - a. Auction accepts no responsibility for non-titled vehicles sold without title. Seller must announce the vehicle being sold with a bill of sale only and that there is no title to transfer.
 - b. All non-titled vehicles and equipment will be sold "AS-IS".
8. **Titles Not Permitted:**
 - a. Applications or other documents related to a duplicate title will not be accepted (*unless announced as such or if allowed by the appropriate jurisdiction*).
 - b. Foreign titles, such as Canadian titles, are unacceptable.
9. **Assignment Title Timelines**
 - a. Seller has up to a maximum of 30 calendar days for title to be received by Auction [*sale day is day (1)*].
 - b. After the 30 calendar day period, it is the Buyer's option to return the vehicle or wait a reasonable period of time for the title.
 - c. **Buyer Responsibilities:** The Seller/Auction shall not be liable for any vehicle sale or repairs made by the buyer before the title is received by the buyer. If the title has been mailed from Auction to Buyer, Buyer may not return vehicle. Buyer is required to notify Auction in a timely manner consistent with Auction policy before returning vehicles. If a valid negotiable title is presented within the Auction policy notice period, the transaction will stand.
 - d. If, after 90 calendar days, Seller has not produced negotiable title and Buyer has not returned the vehicle, this title guarantee shall not apply and Auction shall have no duty to produce the certificate of title to the Buyer and shall have no duty to pay Seller.
10. **Seller Title Disclosures – (Subject to Auction Title Policy):**
 - a. Vehicles lacking a properly assigned title or reassignment to transfer a title at time of sale must sell "Title Attached/Title Unavailable/Title Absent", unless announcement is not required within the region.
 - b. Vehicles lacking lien release or a valid repo affidavit for a repossessed vehicle (where allowed by law) must be sold "Title Attached/Title Unavailable/Title Absent", unless announcement is not required within the region.
 - c. Any and all "Title Brands" or discrepancies which may affect a vehicle's value must be announced. Some examples include, but are not limited to: Salvage, Previous Salvage, Not Actual Miles, Odometer replacement, Lemon Law, Rental/For Hire, Reconstructed, Stolen Vehicle, Exempt, Theft Recovery, Flood/Fire histories, disclosure requirements (if required by state; i.e. 25%) and Insurance transfers.
11. **Auction Title Indemnity** - In regard to defect in title, and in any matter relating to odometer mileage, odometer statements, or damage disclosure statements: Seller and Buyer agree to indemnify and hold harmless Auction from any liability, loss costs, damage or expenses, including attorney fees which may arise either directly or indirectly from the sale and purchase of the consigned vehicle including but not limited to title services provided.
12. **Buyer Delivery Responsibility:** Auction will not be responsible for titles mailed from Auction and not received by the Buyer. Buyer has the choice of alternative delivery method and will pay Auction for such service.

13. Seller Additional Fees:

- a. Seller will be responsible for the buy fee plus reasonable transportation expenses to and from the Buyer's dealership to Auction on vehicles returned for "no title".
- b. Titles received after the 30 calendar day period may be subject to a late title fee. All expenses to obtain title will be charged to the Seller.

14. Seller Mileage Announcements: Mileage announcements are not required on vehicles deemed exempt from Federal/State Odometer and Title disclosure laws unless a mileage discrepancy is known or apparent to the seller. The Seller may represent miles on exempt vehicles – any statement made by the Seller and all known odometer discrepancies are grounds for arbitration.

V. Gray Market & Canadian Vehicles

1. **Eligible Vehicles** - Only vehicles made in North America for Canadian use and properly converted to U.S. specifications can be sold and must be announced as such. No other Gray Market vehicles are accepted for sale.
2. **Seller Responsibilities:** Seller must inform Auction that a vehicle has Canadian history at time of registration and must disclose that to the Buyer in writing as an announced condition on the block ticket unless the car is (5) years or older.

3. Proper Conversion

- a. If a vehicle was manufactured in Canada for the Canadian Market, the Manufacturer is required to obtain and affix a U.S. Safety Standard Certification Label to the vehicle.
 - b. All other vehicles imported from Canada must be imported through a Registered Importer. Registered Importers are required to post a bond with the U.S. Department of Transportation. All vehicles imported through a Registered Importer must have:
 - i. U.S. Safety Standard Certification Label that identifies the Registered Importer
 - ii. Valid U.S. Title
 - c. All Canadian vehicles, whether imported by a Manufacturer or a Registered Importer, must show miles per hour on the speedometer and miles traveled on the odometer. Title 49, United States Code, Chapter 327, Section 32704, allows replacement odometers without a door frame sticker if the conversion from kilometers to miles can be done without changing the distance traveled by the vehicle; therefore, replacement of an odometer under these circumstances does not have to be announced by the Seller.
4. "Gray Market Vehicles" will not be accepted for sale unless they meet ALL Federal D.O.T. / E.P.A. Mandated Guidelines. Documentation must be provided. Sellers will not offer for sale any European manufactured vehicles.

Appendix I. Arbitration Matrix

NAAA Seller Disclosure Requirements	Disclosure	Required	Arbitration	Period
	Green Light	Red Light	Green Light	Red Light
	R/D	As-Is	R/D	As-Is
Mechanical/Electrical problems*	Yes	No	A/C	N/A
Sludged engine	Yes	No	A/C	N/A
Cracked or repaired block	Yes	No	A/C	N/A
Vehicles not equipped with air conditioning (calendar year or newer)	Yes	No	A/C	N/A
Paintwork (3 panels or more) on current model year And newer (bumpers not included)	Yes	No	A/C	N/A
Fuel Conversion	Yes	No	B/C	N/A
Non-original engine (excludes items replaced under manufacturer warranty) Calendar year & up to 4 years old	Yes	No	B/C	N/A
Voided factory warranty	Yes	No	B/C	N/A
Logo or decal misrepresentation	Yes	Yes	A/C	A/C
Bio-Hazard vehicles (both cleaned and contaminated) as required by law	Yes	Yes	A/C	A/C
Frame/Unibody Damage (existing, altered, or repaired) Per NAAA policy	Yes	Yes	B/C	B/C
Flood Damage (By Auction inspection)	Yes	Yes	B/C	B/C
State-issued VIN plates (including kit vehicles)	Yes	Yes	B/C	B/C
Taxis, Livery vehicles, Police cars, Government vehicles that Are Calendar year and up to 4 years old	Yes	Yes	B/C	B/C
Previous Canadian that are calendar year and up to 4 years old (unless state or local law supersede)	Yes	Yes	B/C	B/C
Lemon Law/Manufacturer's Buyback	Yes	Yes	B/C	B/C
Vehicles being sold with no title (Bill of Sale only)	Yes	Yes	B/C	B/C
Not Actual Miles/Inoperative Odometer**	Yes	Yes	B/C	B/C
Salvage or Reconstructed/Theft Recovery/Stolen vehicles (including history)**	Yes	Yes	B/C	B/C
Gray market vehicles**	Yes	Yes	B/C	B/C
Insurance and/or Salvage titles (including history)**	Yes	Yes	B/C	B/C
Vehicles being sold with a CO, MSO, or repo affidavit title (if required by state law)	Yes	Yes	7 days after receipt of title	7 days after receipt of title
Pending state or local DMV fees or taxes over \$100 due on vehicle (if required by state)	Yes	Yes	7 days after receipt of title	7 days after receipt of title
Any state required damage disclosure	Yes	Yes	7 days after receipt of title	7 days after receipt of title
Flood Damage history (discovered by DMV or Insurance company records)	Yes	Yes	120 Days	120 Days
Items subject to arbitration Online ONLY				
Glass damage/Hail damage/Tire Problems*	Yes	No	C	N/A
Upholstery problems/Visible body damage*	Yes	No	C	N/A
Arbitration Period				
A: In-Lane - Sale Day Only				
B: In-Lane - 7 calendar days				
C: Online - 2 calendar days upon verified receipt not to exceed 10 calendar days from purchase				
*In-Lane must announce defects that are singularly \$500 or more to repair				
*On-Line must announce defects that are cumulatively \$500 or more to repair				
**These transactions can be rescinded if arbitrated within the stated time limits. Arbitrations initiated after the stated time period will be addressed via the depreciation formula described in Section IV (Title Arbitration Policy section)				

Appendix II – NAAA Recommended Structural Damage Policy

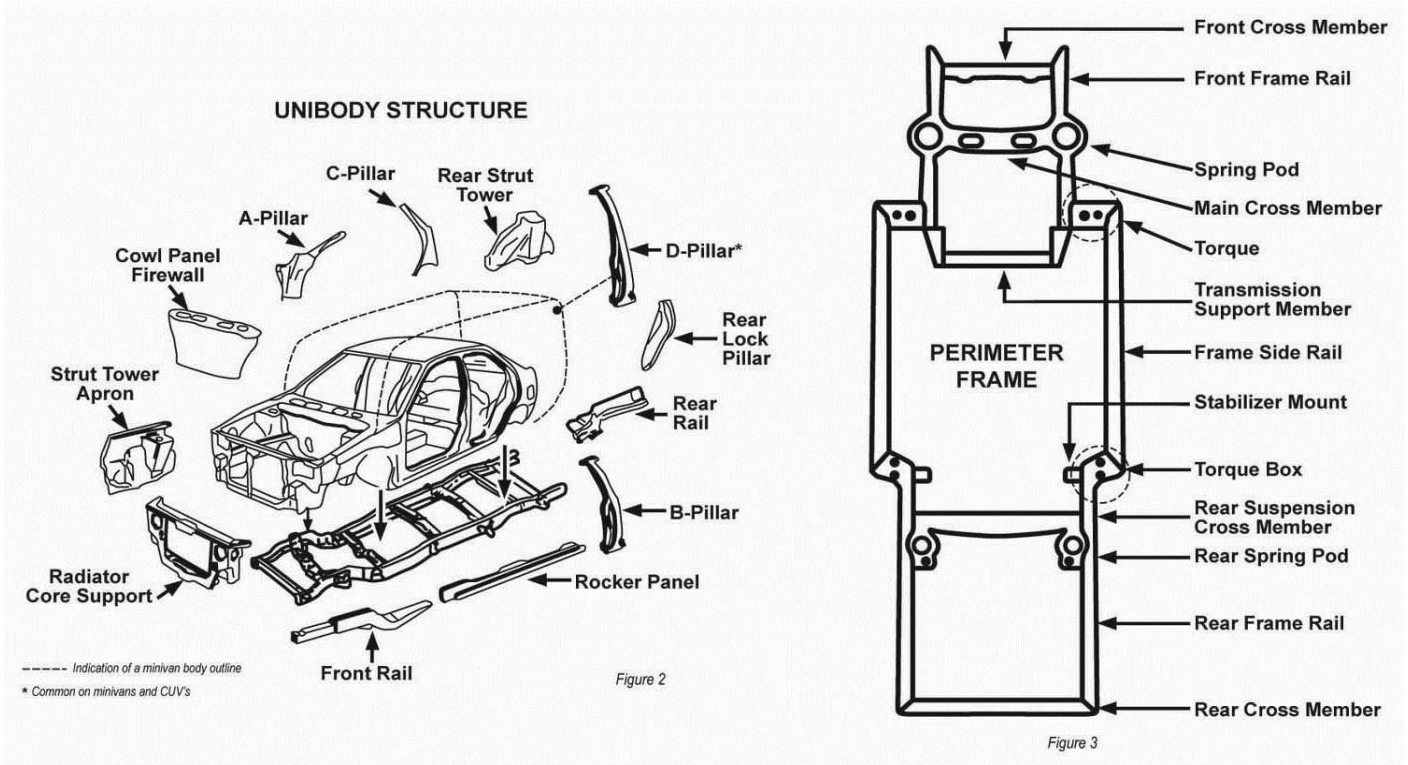

Component	Disclosure Requirement		
	Unibody	Unibody on Frame	Conventional Frame
1. Radiator Core Support – Including the upper and lower tie bars, center support or side baffles		None	
2. Frame Rails Extensions (Ears) – On frame vehicles that area at the end of the frame rail to which the bumper, reinforcement or isolators attach.		None	
3. Frame Rails – Including front, center & rear rails.		Existing or repaired damage, or replacement	
4. Spring Pod, and Torque Box or Stabilizer Mount	N/A	Existing or repaired damage, or replacement	
5. Cross members – Except Bolt-Ons	N/A	Existing or repaired damage, or replacement	
6. Apron/Upper Reinforcement Rails	Existing or repaired damage, or replacement	None	
7. Strut Tower	Existing or repaired damage, or replacement	None	
8. Cowl Panel / Firewall – excluding cowl vent panel	Existing or repaired damage, or replacement	None	
9. Support Pillars – “A”, “B”, “C” or “D” Pillars	Existing or repaired damage, or replacement		
10. Roof	Replacement		
11. Rocker Panel – Outer	Replacement		None
12. Rocker Panel – Inner	Existing or repaired damage, or replacement		None
13. Floor Panels	Torn and/or perforated if 1” or more, dented if deflected more than 2” or replacement floor panel		None
14. Quarter or Cab Panel	Replacement		None
15. Rear Body Panel	None		